

Orig



Amoco Production Company

Research Department

COLD FUSION: REPORT ON A RECENT AMOCO EXPERIMENT

By

Theodore V. Lautzenhiser
Daniel W. Phelps

New Energy Times

TABLE OF CONTENTS

	<u>Page</u>
Summary	1
Brief History	1
Amoco History	1
Detailed Experiment	2
Calorimetric Cell	2
Data Collection System	3
Electrolytic Cell Construction	3
Materials	4
Experimental Procedure	4
Results	5
Calorimetric	5
Tritium	7
Palladium Electrode	8
Lithium	8
Discussion	8
Acknowledgements	9
Bibliography	9

SUMMARY

This report will discuss briefly some of the early calorimetric experiments on cold fusion and in more detail, a single experiment just concluded.

A closed cell electrolytic experiment has been conducted using a palladium cathode and platinum anode with accurate (± 0.001 watt) calorimetric measurements. Results indicate a positive energy output of approximately 50 Kjoules more than was input to the experiment through electrolysis current and heater current. The heat output was observed both as short term bursts of energy and as long term sustained production. Colorimetric calibration with an internal heat source showed essentially identical data before and after the electrolysis experiment. Material balance for palladium, water and lithium showed essentially no material had been consumed during the experiment. Tritium levels measured before and after electrolysis showed a factor of 3 increase that cannot be accounted for by concentration effects.

It is important to note that if this experiment had been terminated after only one month the results would have shown no positive energy production.

These data support the claims of several experimenters that anomalous heat and tritium are produced during electrolytic experiments using a hydrogen absorbing cathode. Further experiments are in progress to determine reproducibility and better define experimental parameters.

BRIEF HISTORY

Cold fusion burst upon the scene with great fanfare and little hard information with a press conference in March 1989, when Pons and Fleischmann (1) announced they had found anomalous energy associated with an electrochemical cell. Before there were any actual reports in the literature, circulation of the preprints was commonplace. There were several claims of confirmation over the following few months from diverse groups located worldwide (2-9). At the same time there were many statements that "cold fusion", at best, was the result of experimental error (10-19). Since many "experts" have come out saying that there is nothing to cold fusion, the public perception at this time is that cold fusion has mostly faded away.

AMOCO HISTORY

In April 1989, a "garage experiment" on cold fusion was set up by Ted Lautzenhiser of Amoco and Melvin Eisner of the University of Houston on the basis of a common interest in a scientific curiosity. This experiment yielded a 30% energy gain over the life of the the experiment (two months). The calculation of the energy gain depended upon assigning an energy to the dissociation of heavy water into its components, deuterium

Proprietary - for the exclusive use of Amoco Production Company and other wholly owned subsidiaries of Amoco Corporation.

and oxygen. This is in common with most of the published experiments, although a platinum surface had been provided for the catalysis of the gases back to heavy water. The surface area of the catalyst had proven to be insufficient and the volume of the electrolyte had been diminished by the electrolysis. Concurrent with this experiment an idea for a possible commercially valuable process was mutually conceived. At this point, the work was disclosed to Amoco TRC management and support was given to continue the investigation of cold fusion as an Amoco project.

In June 1989, the first experimental modification was to the catalyst after the experiment was moved from Houston to the Amoco TRC laboratories. This catalyst consisted of platinum powder packed into a glass tube with the gases evolved from the electrolytic cell being forced through the tube. This catalyst appeared to work effectively and the experiment was again yielding about 30% excess energy until the catalyst became water logged and channeling of the gases through the platinum powder caused the catalyst to fail. However, the energy gain without "bookkeeping" had been shown, although only briefly.

In August 1989, a new catalyst was constructed using platinum powder ground into a fiberglass matrix. This unit allowed the water formed to drip back into the electrolytic cell. Because the catalyst was now bigger than envisioned at the beginning of the experiment the calorimetric chamber had to be modified to allow for the electrolytic cell and catalytic unit to be enclosed. The energy gain during this experiment was 10%, but it was felt that the modifications to the calorimetric chamber had introduced an error such that the energy gain determined was conservative. It should be noted that all of these experiments used the same palladium ingot purchased by Lautzenhiser and Eisner in Houston. At this time a new calorimetric cell was built and the the following experiment was begun.

DETAILED EXPERIMENT

CALORIMETRIC CELL

The determination of the energy balance was accomplished through a calorimetric cell. This cell, shown in Figure C1 (90080ART0182), consisted of an thick walled aluminum cylindrical chamber (1) connected to an aluminum plate (2) with 3 brass bolts (3) passing through 2 inches of insulation (4). This assembly is placed inside an insulated chamber (5) which is surrounded on all sides except the bottom by a water jacket (6). This is set upon another inch layer of insulation. The water jacket has a forced circulation of water maintained to within $\pm 0.0005^{\circ}\text{C}$. This water jacket is surrounded by an inch layer of insulation (7). A thermistor probe (8) was inserted through a tee at the water outlet (9).

In operation, the inner aluminum chamber is maintained at a constant temperature difference above that of the aluminum plate to which it is attached with the brass bolts. These bolts serve as the primary thermal

Proprietary - for the exclusive use of Amoco Production Company and other wholly owned subsidiaries of Amoco Corporation.

energy conduction path from the aluminum chamber to the aluminum plate which is in close proximity to the water jacket. The aluminum plate is not in direct contact with the water jacket in order to soften the effect of the circulating water temperature excursions upon the calorimeter. The temperature difference between the plate and the aluminum chamber is then representative of the heat flow from the chamber to the plate and from there to the water jacket. A computer controlled power supply supplied power to a resistor within the chamber and supplied power such that the electrolytic cell temperature was maintained at 10°C above the plate temperature. This required a power of $2.486 \pm .001$ watts.

DATA COLLECTION SYSTEM

The data collection system was based on a AST Premium/286 computer which controlled an Hewlett Packard bus system. On this bus was an analog signal multiplexor (HP-3488A), a multimeter (HP-3478A), and a four channel controllable power supply (HP-6624A). This system was programmed to monitor the required voltages, currents, and temperatures of the experiment. The temperature difference between the calorimeter chamber and top plate was then used to control the power supplied to the calorimeter resistor in order to maintain that difference at 10° . Every 5 minutes data stored on hard disk was backed-up to a floppy disk. The information was displayed to a screen in both graphic and tabular form for real time monitoring. The floppy disk was used to transfer the data to another PC system for data analysis and transfer to the mainframe.

ELECTROLYTIC CELL CONSTRUCTION

The electrolytic cell shown in Figure C2 (90080ART0180) was a two piece design constructed from 50 mm O-ring pyrex glass joints. The O-rings (3) are FETPE and were size 229. The lower glass piece (1) was constructed with a flat bottom and was 50 mm long. The top (2) was rounded about 20 mm from the O-ring and two 7 mm threaded glass connectors were attached extending up about 20 mm. The two cell halves were clamped together by two donuts (11) machined from nylon. Four 10 x 32 screws were used to secure the donuts together. The cell was designed to have an internal recombination catalyst (4) to eliminate water material balance calculations. A catalyst tube was constructed from 18 mm OD and 7 mm OD pyrex glass tubing. The 18 mm glass was reduced down to connect to the 7 mm glass which could pass through and be sealed in the 7 mm threaded connector. The wide bore of the catalyst tube was 20 mm long and loosely packed with pyrex glass wool and platinum sponge (99.95%, 60 mesh, Atlantic Metals). A piece of platinum gauze (52 mesh, 99.9%, Aldrich # 29,810-7) was wedged under the glass wool and a 2 mm glass rod attached across the bottom of the catalyst tube to assure that the catalyst could not drop into the electrolyte.

A short piece of 7 mm OD glass tubing (5) was put in the second 7 mm threaded connector. Both the catalyst tube and the 7 mm open tube were

Proprietary - for the exclusive use of Amoco Production Company and other wholly owned subsidiaries of Amoco Corporation.

connected with 1/4 X 1/8 inch Swagelok Teflon reducing unions (6) to 1/8 inch Teflon tubing (7) that ran out of the calorimetric cell.

A PTFE Teflon holder (10) was machined to hold the Pd ingot (9) in the center of the electrolytic cell and assure no contact with the anode (8). The holder had a 45 mm base 5 mm thick with four fingers extending upward to hold the ingot.

MATERIALS

Platinum (52 mesh, Aldrich) was used as the anode. Pieces of gauze were spot welded together and to 0.5 mm platinum wire (99.9%, Aldrich # 26,722-8) to form a cylinder shape 48 mm diameter and 40 mm high. A piece of the 0.5 mm platinum wire was passed through a 0.5 mm hole in the PTFE O-ring to connect to the power supply.

Palladium was purchased from Atlantic Metals and Alloys, Inc., in the form of a cylindrical ingot. The ingot was 37 mm in diameter, 13 mm deep and machined on the bottom and sides but left as originally cast on top. The metal was vacuum-induction melted in a ceramic crucible and rapidly cooled to insure a fine grained microstructure. Analysis showed the grain size varied from 0.150 to 0.200 mm. The purity was 99.9% with a carbon level of less than 30 ppm. Other metals as impurities were; Pt < 100 ppm, Rh < 100 ppm, Ru < 100 ppm, Ir < 100 ppm, Au < 200 ppm, Fe < 50 ppm and Cu < 50 ppm. A 0.5 mm platinum wire was spot welded onto the Pd ingot and fed through a 0.5 mm hole in the PTFE O-ring to connect to the power supply.

The electrolyte was made from 99.95% deuterated water purchased from Atlantic Metals and Alloys, Inc. This water was kept under an argon atmosphere. An in-house NMR analysis showed the purity to be 99.96%. Lithium metal (99.5%, Alfa # 00733) as 1-6 mm granules was reacted with the heavy water from Atlantic Metals to make LiOD. The process was done in a glovebox under positive argon gas flow. Approximately 22 grams of lithium metal was reacted with one liter of D2O to make the electrolyte. This solution is about 3 molar LiOD which is less than the saturation concentration of 4 molar.

EXPERIMENTAL PROCEDURE

The electrochemical cell was loaded with electrolyte and placed within the calorimetric chamber. The calorimeter was then allowed to stabilize with no electrolysis current while the calibration on the calorimeter was determined. It was found that 2.486 watts of power was required to keep the chamber at its constant temperature difference of 10°C relative to the outer plate.

The electrolytic cell current was then turned on, and over a period of two months the current was changed occasionally. The current and voltage supplied to the electrolytic cell, the current and voltage supplied to the calorimetric resistor, and the temperatures of the water jacket, calorimeter

Proprietary - for the exclusive use of Amoco Production Company and other wholly owned subsidiaries of Amoco Corporation.

tric chamber, calorimetric plate, and the electrolytic cell were measured and recorded by the data system. At the end of two months the electrolytic current was turned off and the calibration of the calorimeter was rechecked after the experiment had reached its null equilibrium.

Analysis of the electrolyte for tritium was done by Teledyne Isotopes in Westwood, NJ. The analysis was done by liquid scintillation counting. Results have been corrected for counter efficiency and background of the scintillation cocktail.

Analysis of the electrolyte for platinum and palladium was done by standard ICP (inductive coupled plasma) analysis using a Perkin Elmer model 6000. The 306.471 nm emission wavelength was used for platinum and the 340.458 nm wavelength was used for palladium. Standards were purchased from Alfa Products at a concentration of 1000 ppm. Appropriate dilutions were made to make a standard curve ranging from 5 to 100 ppm. The samples were analyzed without dilution or other preparation.

Lithium analysis was also done by ICP. Standards were run at 1000 and 500 ppm. The samples were diluted to be within this range. The 460.286 nm wavelength was used for lithium analysis.

Surface analysis was done by X-ray fluorescence using a Kevex Model 7000 instrument with an ISI model 100 microscope. The X-ray energy was 25 Kev and 1 position of about 500 microns diameter on the unmachined surface was examined. A concentration of impurities greater than 1% would have been detected under the conditions used.

RESULTS

CALORIMETRIC

The current is plotted versus time in Figure R1 (90079ART0295). At the start of the plot, on October 24, the period of time over which the current is zero is shown. This is the calorimeter calibration period. Afterwards, the current is increased to 100 ma and then to 500 ma. Further changes are shown until the current was reduced to zero on December 7.

Also plotted in Figure R1 is the sum of the energy dissipated in the calorimeter resistor and the energy electrically delivered to the electrolytic cell minus the thermal energy lost at a constant rate of 2.486 watts from the calorimeter. This is then the net energy delivered to the calorimetric cell.

Plotted in Figure R2 (90079ART0296) is the same energy curve as is plotted in Figure R1 along with the power curve representing the sum of the power dissipated in the calorimeter resistor and the power fed into the electrolytic cell. The line labeled Thermal Loss Rate represents the 2.486 watt power level that represents the calibrated power loss rate of the calorim-

Proprietary - for the exclusive use of Amoco Production Company and other wholly owned subsidiaries of Amoco Corporation.

eter. If the net power in is greater than the 2.486 watt, the electrochemical cell is storing energy. On the other hand, if the net-power-in is less than the 2.486 watt, the electrochemical cell is delivering more power than it is receiving. The time integral of the net-power-in curve minus the thermal loss rate is the energy curve.

The data from the first day is shown in Figure R3 (90079ART0297). This is the initial calibration period of the experiment; the current is seen to be zero until about 0900 on October 25, at which time the current is increased to 100 ma. The power line can be seen to approach the 2.486 watt line as the calorimeter is allowed to settle and then basically trace a straight line until the current is turned on. The average of this power from 1500 on October 27 until turn on is the 2.486 watts that is the thermal loss rate of the calorimeter.

In Figure R2, after the spikes associated with the power transition of the current turn on, there is a period of several days during which the power line, being above the 2.486 watt line, is showing that the electrochemical cell is storing energy. This energy is that of the dissociation of the heavy water into oxygen and deuterium and the storage of deuterium within the palladium anode. This requires that the oxygen of the dissociated water be vented from the cell just as in a storage battery. This charging energy can be reclaimed from the system by allowing the deuterium within the palladium to be released and then recombined with the oxygen on the catalyst. This part of the power curve is then much like that which would be observed if the electrochemical cell were a storage battery, which indeed the electrochemical cell is.

On October 27, the current is increased to 500 ma. Again there is a period of enhanced energy charging of the cell followed by a decay. The current was then turned down and the cell continued to accept energy, though at a lesser rate. After the cell had basically reached an equilibrium charge, the current was increased to 400 ma. The cell began to accept energy at a low rate, and then over a period of about a month, was at an equilibrium state with little changes in the net energy in from the 2.486 thermal loss rate.

On November 21, as shown in Figure R4 (90079ART0298), the current was reduced to 40 ma. As can be seen, the net power in required to keep the calorimeter at its constant temperature fell to 100 mw less than the thermal loss rate. This means that after the transition, the cell yielded power at approximately 100 mw for a period of 8 hours. At that time, the net power again approached the 2.486 watt net power input line, but with a residual power output from the cell. Over the period of the next week, the cell gradually increased its power output as shown by the gradual decrease in power required to keep the calorimeter at a constant temperature.

On December 1, as shown in Figure R5 (90079ART0302), there was a transition event in the power. This occurred without changing any input param-

Proprietary - for the exclusive use of Amoco Production Company and other wholly owned subsidiaries of Amoco Corporation.

ters. The cell over a period of less than 2 hours began to produce power at about 90 mw versus the 40 mw it had built up to over the previous week. This transition event occurred over about a two hour span.

Then as shown in Figure R6 (90079ART0305), there was another spontaneous transition event and the power production from the cell fell to approximately 60 mw rate. Here the power level remained till December 7, when the current was shut off.

After current shut off, the cell continued to produce power for about a week. This power in large part was probably due to the release of the deuterium from the palladium and the subsequent catalytic recombination with oxygen. However, the energy released after the current shutoff was greater than the 25 Kj that had apparently been used to charge the cell at the beginning of the experiment.

In Figure R7 (90079ART0306), the period starting at 1000 on December 17 is shown. This is about a week after the electrolyzing current has been shut off. The net power in has again returned to the 2.486 watt line as during the calibration period. It might be noticed that it is actually a little above 2.486 watts indicating perhaps the extent of the drift of the calorimeter system or perhaps indicating that during the original calibration there had been a background power release from the cell due to a chemical reaction. This effect would make calculation of the energy produced pessimistic by about 20 Kjoules.

TRITIUM

The electrolyte was analyzed for tritium activity before and after the experiment. Prior to starting the experiment the electrolyte had a value of 2.5 ± 1.0 pcurie/mL. After the experiment was completed, a sample of the electrolyte was counted again and was found to have 7.4 ± 1.1 pcurie/mL. While not a large increase in tritium, this increase is significant.

The system was not closed to restrict gas flow in or out of the cell. But, no concentration of activity could have occurred from the isotope effect because the internal catalyst converted any excess deuterium and oxygen gas produced back into water which remained in the cell. The measured water volume before and after the experiment (80 ml) shows that no concentration of tritium occurred due to losses past the catalyst from possible catalytic inefficiency. Also, gas flow was measured from the catalyst and flow could only be detected during times of rapid charging or discharging of the palladium electrode when stoichiometric volumes of gases were not present.

Thus, the tritium production in this experiment, although small, is real and significant. Three factors make the amount of tritium produced appear less significant. The volume of electrolyte in the cell is large compared to published experiments producing tritium (20). Also, this experiment

Proprietary - for the exclusive use of Amoco Production Company and other wholly owned subsidiaries of Amoco Corporation.

was run on an electrode of much larger volume than those published (21). The charging time for this experiment was a large part of the total experimental time. The experiment was terminated to recalibrate soon after excess heat was observed which would have not given much time for tritium production.

PALLADIUM ELECTRODE

The machined electrode surfaces were not visibly different after the experiment. The surfaces were still the same color and texture as when the experiment was started. The surface left as cast was noticeably smoothed after the experiment. Surface analysis by X-ray fluorescence did not indicate the presence of lithium, platinum or other metals. The electrode was rinsed with water and vacuum dried before analysis. Surface analysis studies of palladium electrodes from similar experiments (22) indicate the surface may be coated with lithium which is rapidly converted to LiOD with no current or an exposure to atmosphere. It is likely that any lithium on the palladium was removed by washing before the analysis.

The electrode was also tested for radioactivity by placing it on radiographic film for 72 hours. No darkening of the film could be detected. However, it is likely that any stored tritium would have been removed during vacuum baking, but this test should have also detected unstable isotopes of the metal if they were formed.

LITHIUM

The electrolyte was analyzed for lithium concentration after the experiment was completed. Analysis by ICP indicated a lithium concentration equivalent to 2.87 M LiOD. This is in good agreement with the 3 M LiOD that was originally used, although the original measurements (22 gm Li in one liter of heavy water) are not of the same accuracy as the post measurement. These numbers are considered in good agreement and indicate that at most very little lithium was consumed during the experiment.

DISCUSSION

The calorimetry conclusively shows excess energy was produced within the electrolytic cell over the period of the experiment. This amount, 50 kilojoules, is such that any chemical reaction would have had to be in near molar amounts to have produced the energy. Chemical analysis shows clearly that no such chemical reactions occurred. The tritium results show that some form of nuclear reactions occurred during the experiment. The tritium produced was not nearly enough to account for the excess energy. The expected nuclear processes would have been on the order of 4 Mev per event. 10^{17} such reactions would have been required to produce 50 Kjoules of energy. Our measurement of tritium shows an excess of 5×10^8 atoms. In other words, tritium production would only account for about 5×10^{-9} of the observed excess energy. The main point of the tritium in this experiment is then that there are some nuclear processes

Proprietary - for the exclusive use of Amoco Production Company and other wholly owned subsidiaries of Amoco Corporation.

involved. Some competing process must be highly favored. A candidate at this time is the Phillips-Oppenheimer type of deuterium-palladium reaction which would, through beta decay, yield silver and hydrogen. Isotopic measurements of the palladium to show the resulting silver would not be possible using known technology, although an experiment run significantly longer at the measured excess power rates would make the possible silver measurable. We hope to test this hypothesis in the near future.

ACKNOWLEDGEMENTS

This is to acknowledge the efforts Tim Stanley, Jim Wirtz, Tony Hambrick and Ralph Wiley put into this effort. Tim Stanley provided valuable insights into some of the metallurgical and electrolytic aspects. Jim Wirtz programmed the data collection system and provided the printouts and plotting of the data for our analysis. Tony Hambrick helped design and built many of the mechanical devices such as the calorimeter and electrolytic cell accessories. Ralph Wiley helped us monitor for possible harmful radiation which was not detected during the period of the experiment.

BIBLIOGRAPHY

1. Fleishmann, M., and Pons, S., Electrochemically induced nuclear fusion of deuterium, *J. Electroanal. Chem.*, 261 (1989) 301-308.
2. Jones, S. E., Palmer, E. P., Czirr, J. B., Decker, D. L., Jensen, G. L., Thorne, J. M., Taylor, S. F., and Rafelski, J., Observation of cold nuclear fusion in condensed matter, *Nature*, 338 (1989) 737-740.
3. Huggins, R., and Scherber, M., DOE Cold Fusion Workshop, Santa Fe, NM, May 25-28, 1989.
4. Appleby, A. J., and Srinivasan, S., DOE Cold Fusion Workshop, Santa Fe, Nm, May 25-28, 1989.
5. Landau, U., Electrochemical Society Meeting, Los Angles, May (1989).
6. Santhanam, K. S. V., Rangarajan J., Braganza, O., Haram, S. K., Limaye, N. M., and Mandal, K. C., Electrochemically initiated cold fusion of deuterium, *Indian J. Tech.*, 27 (1989) 175-177.
7. Adzic, R., Gervasio, D., Bae, I., Cahan, B., and Yeager, B., Investigation of Phenomena Related to D2O Electrolysis at a Palladium Cathode, Electrochemical Society Meeting, Hollywood, Florida, Oct. (1989).
8. Oriani, R. A., Nelson, J. C., Lee, S. K., and Broadhurst, J. H., Calorimetric Measurements of Anomalous Power Produced by Cathodic Charge-

Proprietary - for the exclusive use of Amoco Production Company and other wholly owned subsidiaries of Amoco Corporation.

- ing of Deuterium into Palladium, Electrochemical Society Meeting, Hollywood, Florida, Oct. (1989).
9. Mckubre, M. C. H., Smedley, S. I., Tanzella, F. L., and Weaver, R. D., Calorimetric and Kinetic Observation of D₂-Pressurized LiOD/D₂O/Pd cells, Electrochemical Society Meeting, Hollywood, Florida, Oct. (1989).
 10. Williams, D. E., Findlay, D. J. S., Craston, D. H., Senc, M. R., Bailey, M., Croft, S., Hooton, B. W., Jones, C. P., Kucernak, A. R. J., Mason, J. A., and Taylor, R. I., Upper bounds on 'cold fusion' in electrolytic cells, *Nature*, 342 (1989) 375-342.
 11. Kreysa, G., Marx, G., and Plieth, W., A critical analysis of electrochemical nuclear fusion experiments, *J. Electroanal. Chem.*, 266 (1989) 437-450.
 12. Blaser, J., Haas, J., Petitjean, C., Barbero, C., Bertl, W., Lou, K., Mathias, M., Baumann, P., Daniel, H., Hartmann, J., Hechtel, E., Ackerbauer, P., Kammel, P., Scrinzi, A., Zmeskal, H., Kipfer, R., and Baur, H. and Wieler, R., Experimental Investigation of cold fusion phenomena in palladium, *Chimia*, 43 (1989) 262-268.
 13. Armstrong, R. D., Charles, E. A., Fells, I., Molyneux, L., and Todd, M., A long-term calorimetric study of the electrolysis of D₂O using palladium cube cathodes, *J. Electroanal. Chem.*, 272 (1989) 293-297.
 14. Leggett, A. J., Baum, G., Can solid-state effects enhance the cold-fusion rate?, *Nature*, 340 (1989) 45-46.
 15. Gai, M., Rugari, S. L., France, R. H., Lund, B. J., Zhao, Z., Davenport, A. J., Isaacs, H. S., and Lynn, K. G., Upper limits on neutron and gamma-ray emission from cold fusion, *Nature*, 340 (1989) 29-34.
 16. Zeigler, J. F., Zable, T. H., Cuomo, J. J., Brusio, V. A., Cargill, G. S., III, O'Sullivan, E. J., and Marwick, A. D., Electrochemical Experiments in Cold Nuclear Fusion, *Phys. Rev. Lett.* 62 (1989) 2929-2932.
 17. Lewis, N. S., Barnes, C. A., Heben, M. J., Kumar, A., Lunt, S. R., McManis, G. E., Miskelly, G. M., Penner, R. M., Sailor, M. J., Santangelo, P. G., Shreve, G. A., Tuffs, B. J., Youngquist, M. C., Kavanaugh, R. W., Kellogg, S. E., Vogelaar, R. B., Wang, T. R., Kondrat, R., and New, R., Searches for low-temperature nuclear fusion of deuterium in palladium, *Nature* 340 (1989) 525-530.
 18. Sun, Z., and Tomanek, D., Cold Fusion: How Close Can Deuterium Atoms Come inside Palladium?, *Phys. Rev. Lett.* 63 (1989) 59-61.

Proprietary - for the exclusive use of Amoco Production Company and other wholly owned subsidiaries of Amoco Corporation.

19. Leggett, A. J., and Baum, G., Exact Upper Bound on Barrier Penetration Probabilities in Many-Body Systems: Application to "Cold Fusion", Phys. Rev. Lett. 63 (1989) 191-194.
20. Kainthla, R. C., Velez, O., Kaba, L., Lin, G. H., Packham, N. J. C., Szklarczyk, M., Wass, J., and Bockris, J. O. M., Sporadic Observation of the Fleischmann-Pons Heat Effect, Electrochimica Acta, 34 (1989) 1315-1318.
21. Packham, N. J. C., Wolf, K. L., Wass, J. C., Kainthla, R. C., and Bockris, J. O. M., Production of Tritium from D2O electrolysis at a palladium cathode, J. Electroanal. Chem., 270 (1989) 451-458.
22. Mebrahtu, T., Rodriguez, J. F., Brothwell, M. E., Cheng, I. F., Lawson, D. R., McBride, J. R., Martin, C. R., and Soriaga, M. P., Observations on the surface composition of palladium cathodes after D2O electrolysis in LiOD solutions, J. Electroanal. Chem., 267(1989) 351-357.

Theodore V. Lautzenhiser

Daniel W. Phelps

TVL:tv1/jlp
90081ART0082

Proprietary - for the exclusive use of Amoco Production Company and other wholly owned subsidiaries of Amoco Corporation.

Figure R7. Electrochemical Cell Data from 10 AM 12-17

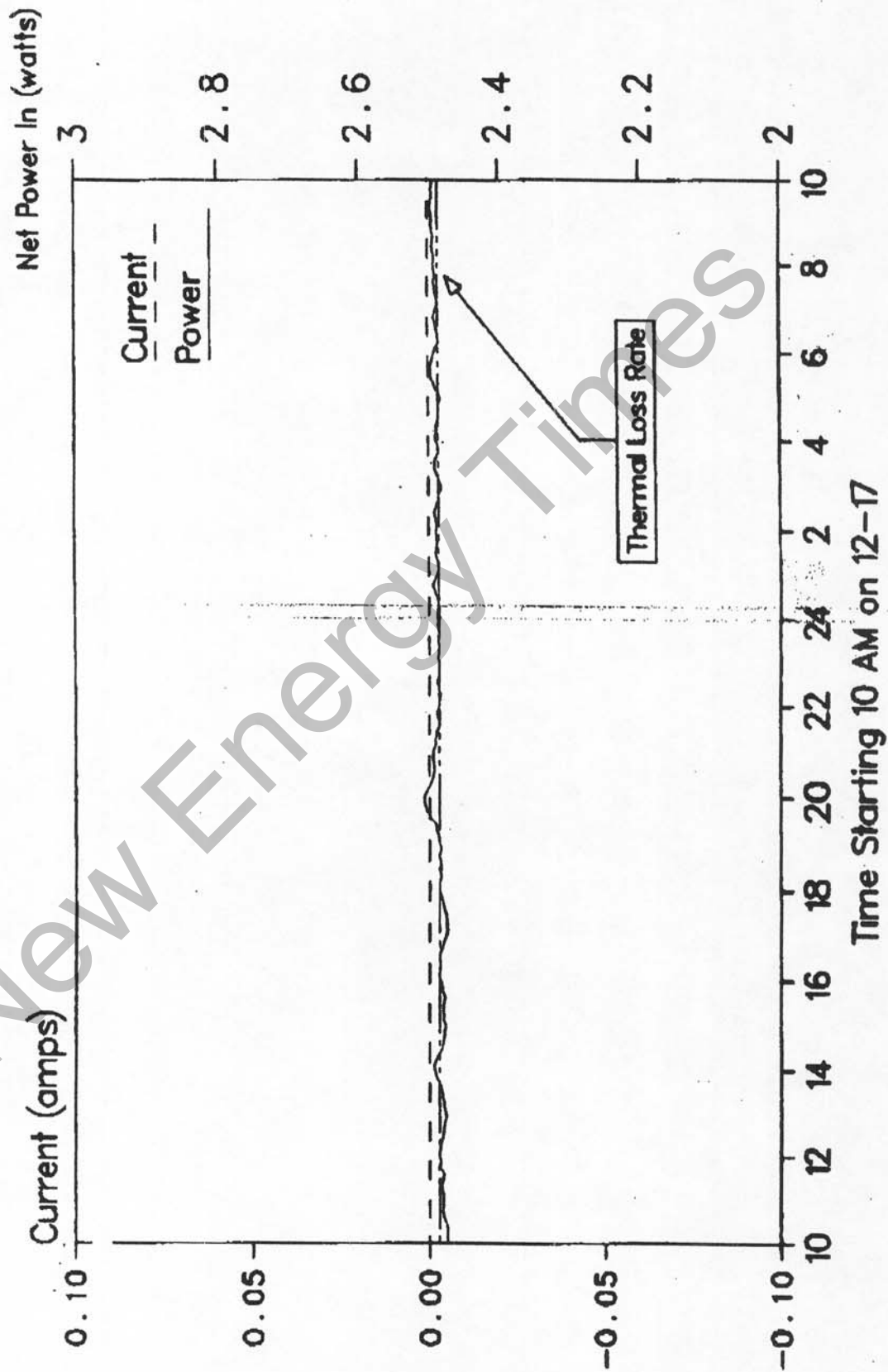

Figure R6. Electrochemical Cell Data for 12-04

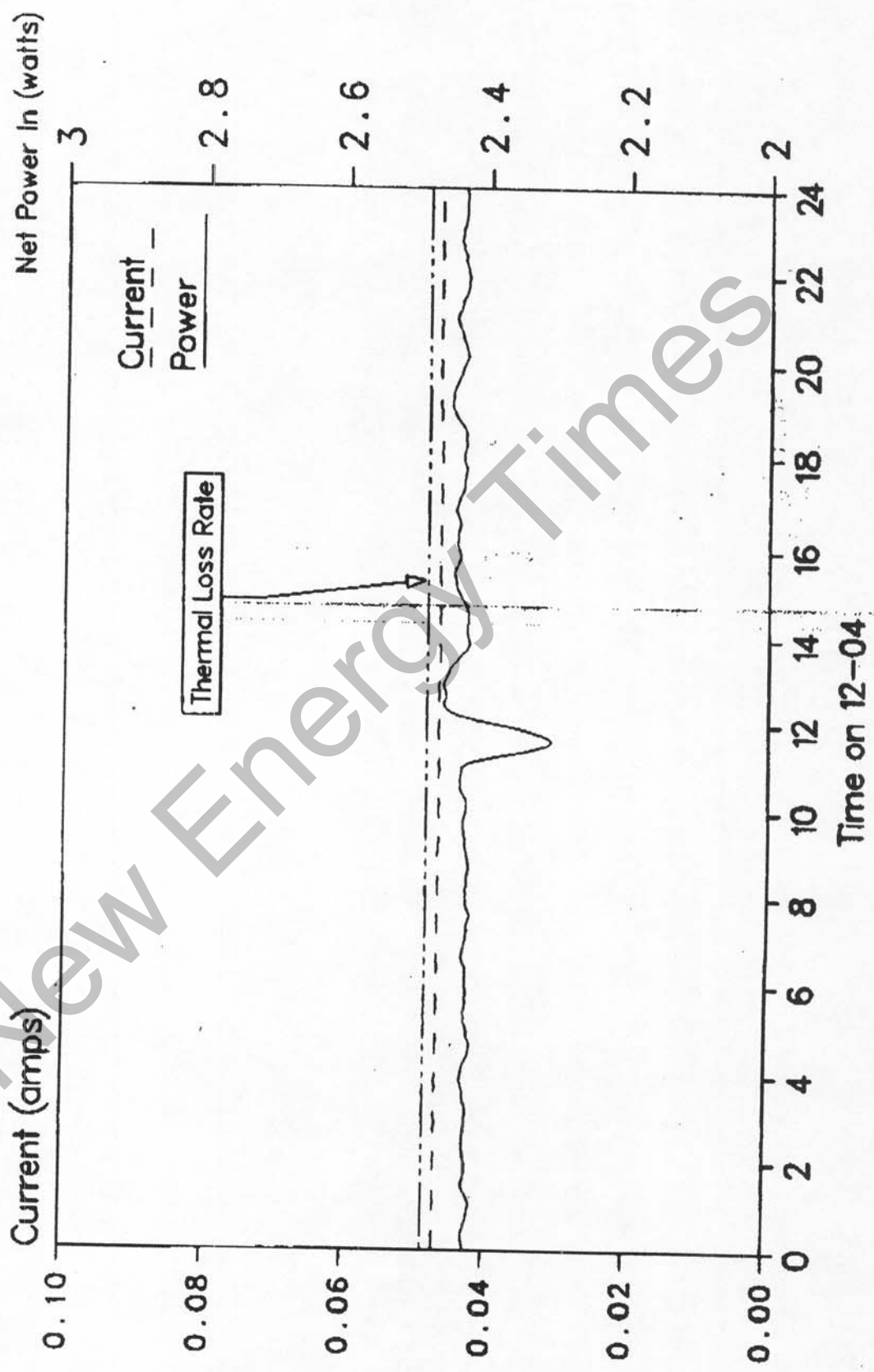

Figure R5. Electrochemical Cell Data for 12-01

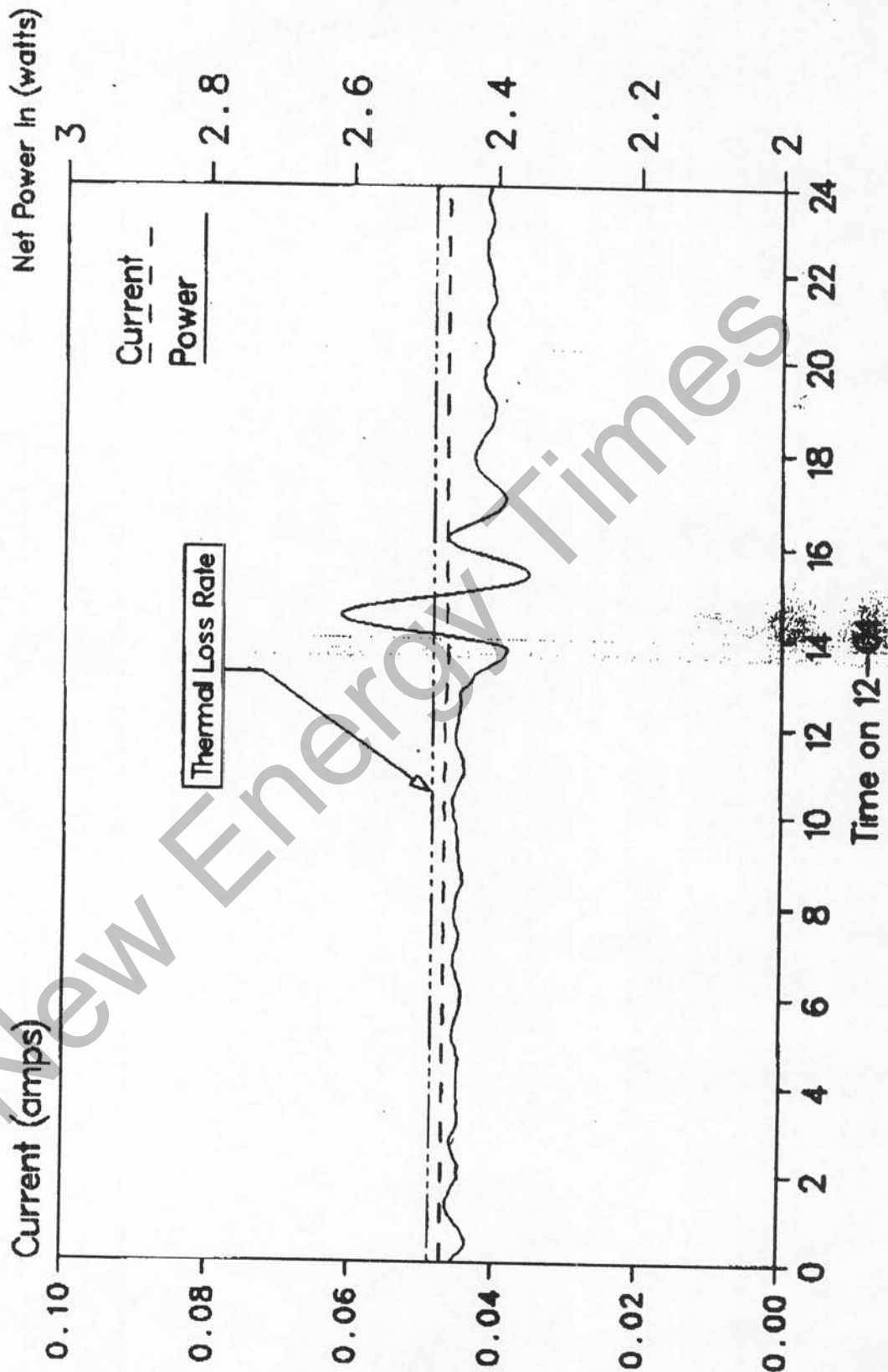
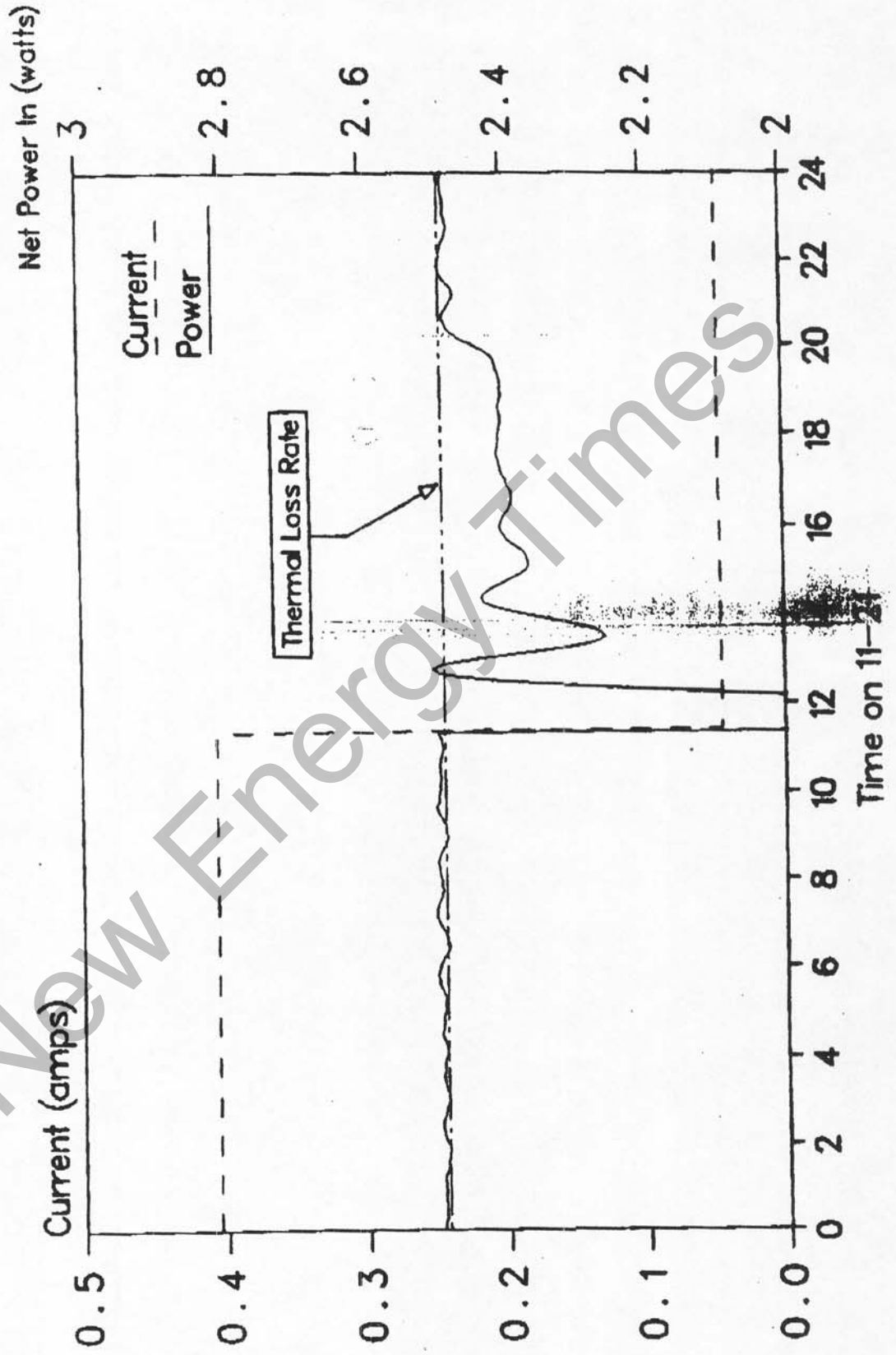

Figure R4. Electrochemical Cell Data for 11-21



MASS BIN-003 FEB 26, 1990 3:51 PM

Figure R3. Electrochemical Cell Data from 9 AM 10-24

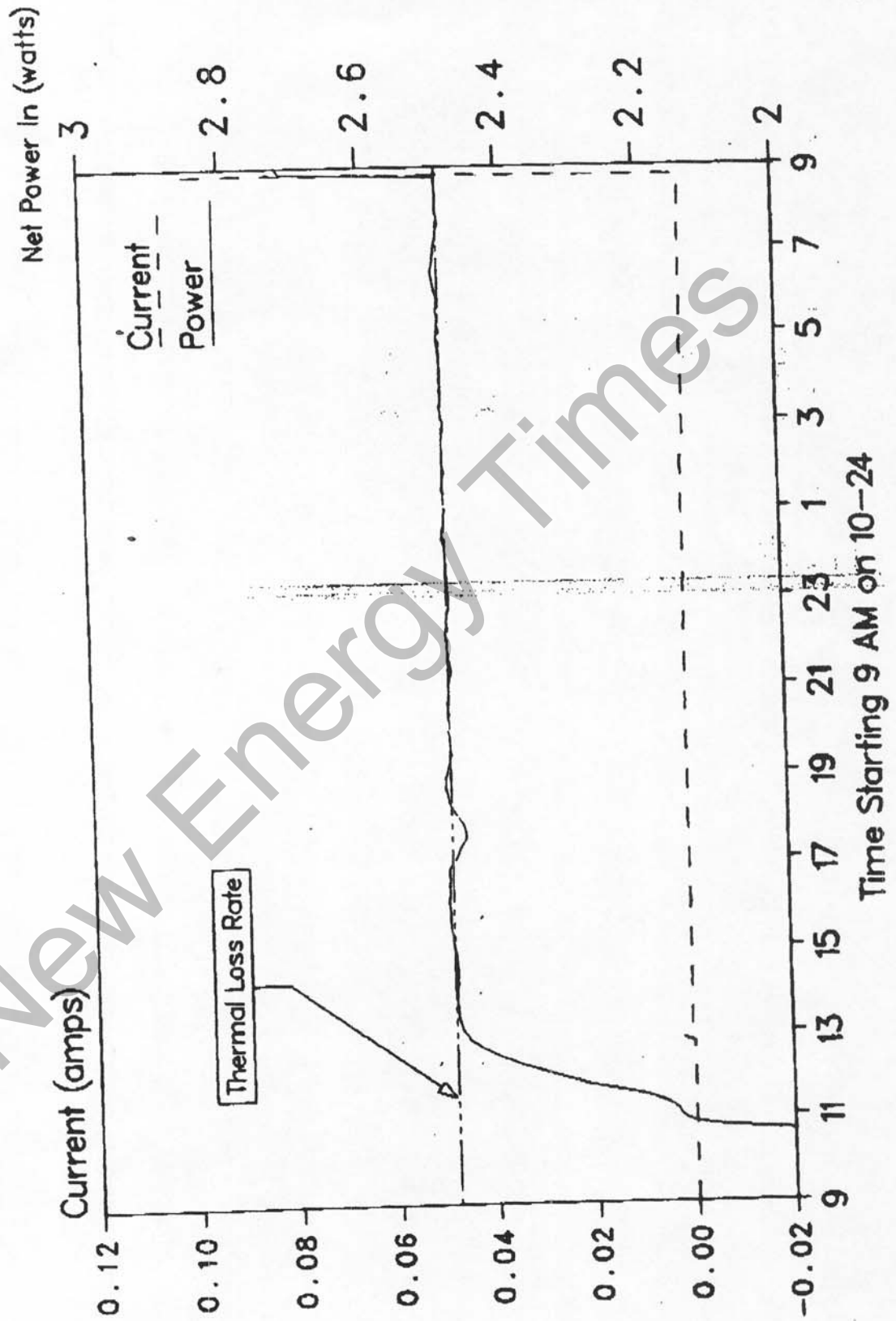

Figure R7. Electrochemical Cell Data from 10 AM 12-17

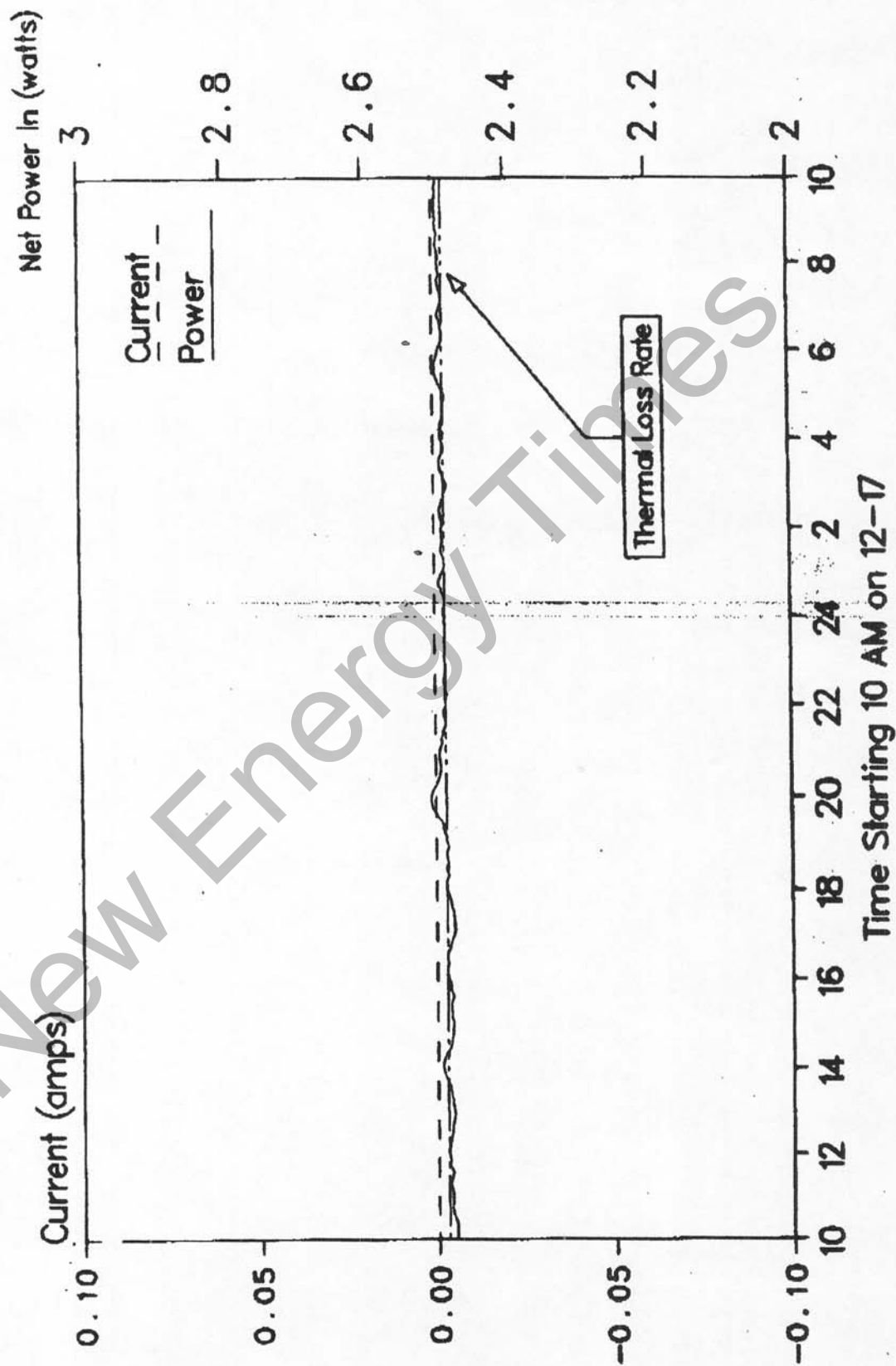
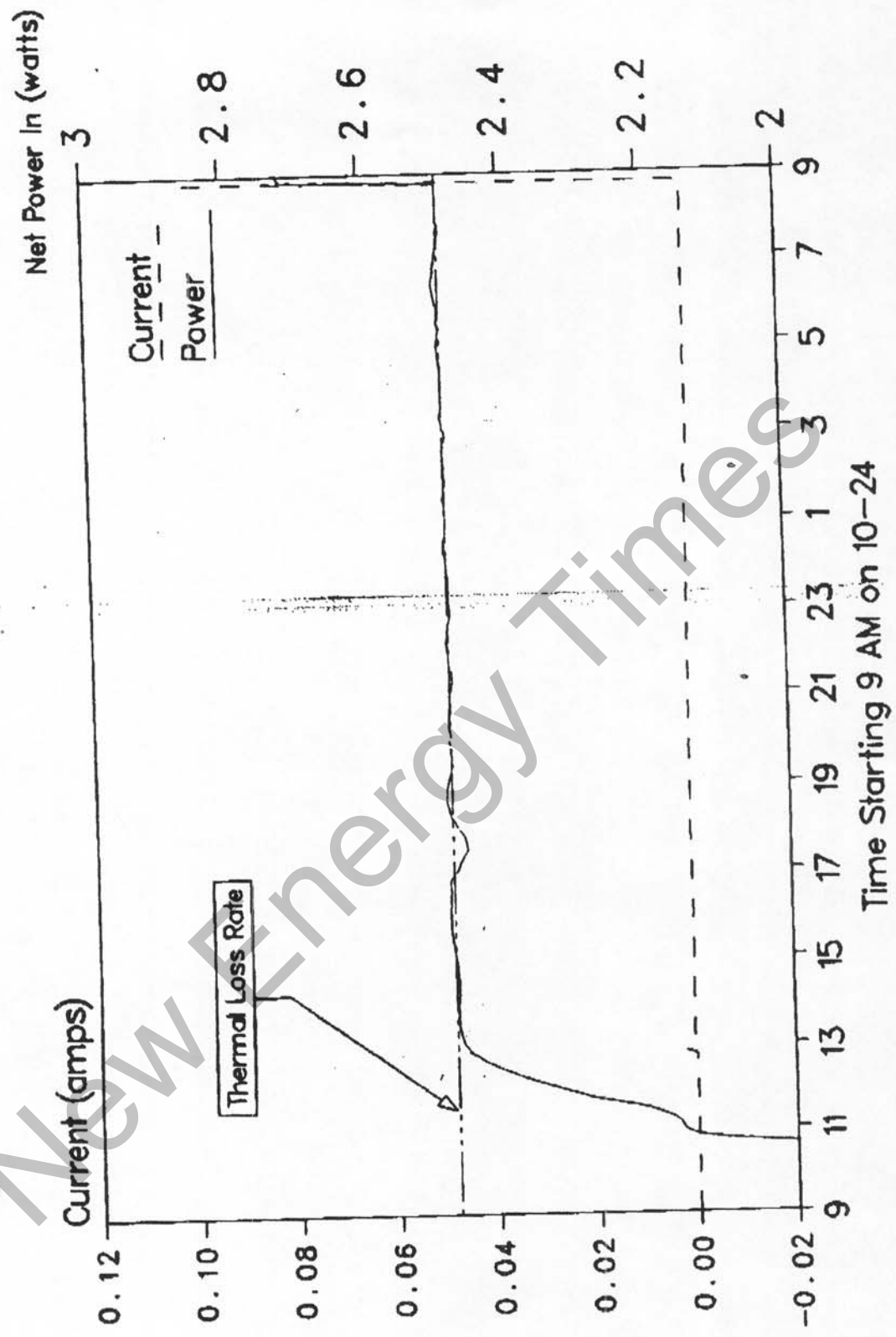
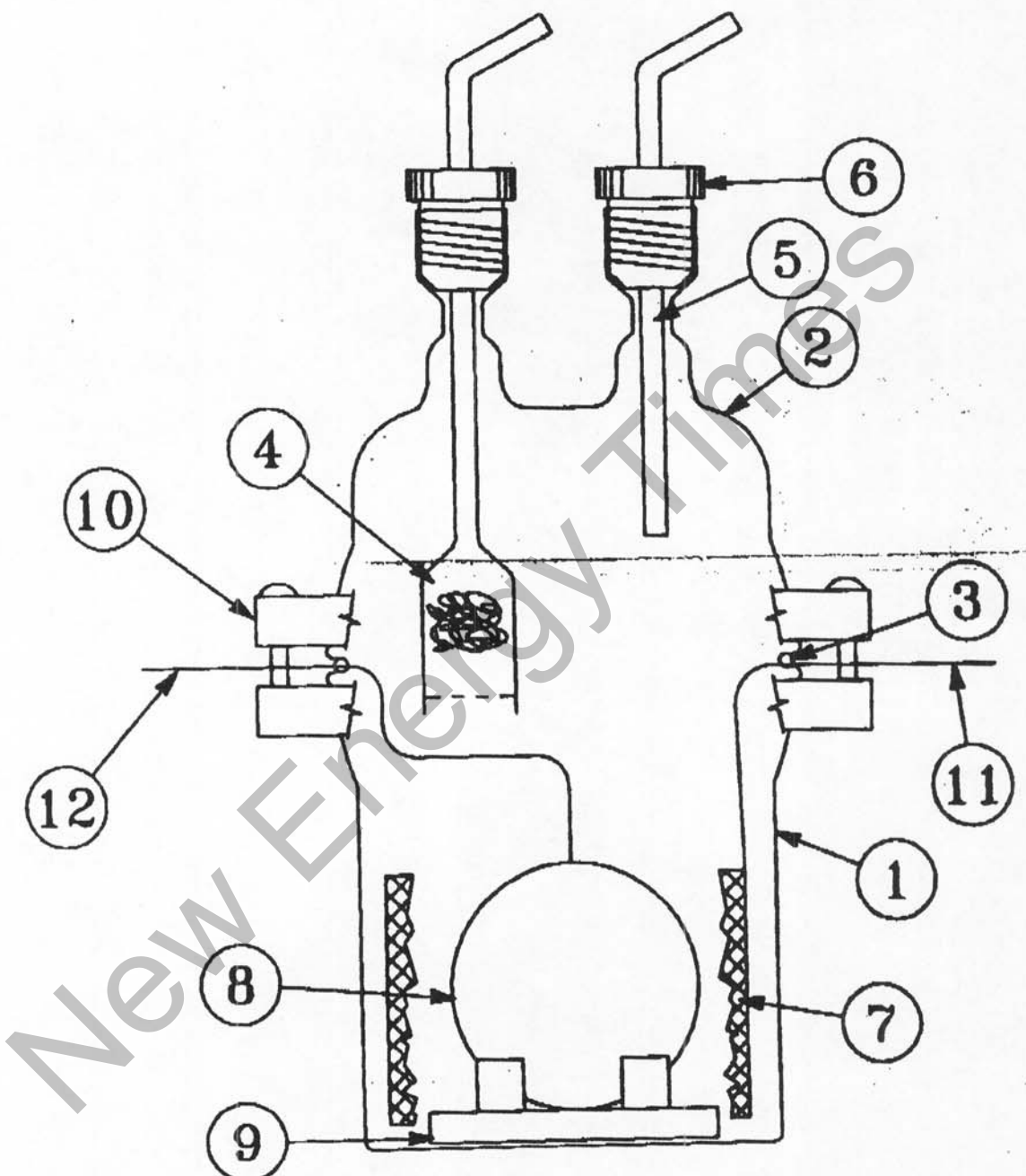

Figure R3. Electrochemical Cell Data from 9 AM 10-24



MASS BTR-003 FEB 26, 1990 3:50 PM

Figure C2 Electrochemical Cell



- | | |
|--------------------------------|----------------------------------|
| (1) BOTTOM CELL HALF | (7) PT ANODE |
| (2) TOP CELL HALF | (8) PD CATHODE |
| (3) PTFE O-RING | (9) TEFLON HOLDER |
| (4) RECOMBINATION CATALYST | (10) NYLON CLAMPS |
| (5) 7mm TUBE | (11) ANODE TO (+) POWER SUPPLY |
| (6) THREADED BUSHING CONNECTOR | (12) CATHODE TO (-) POWER SUPPLY |

Figure C1 Calorimetric Cell

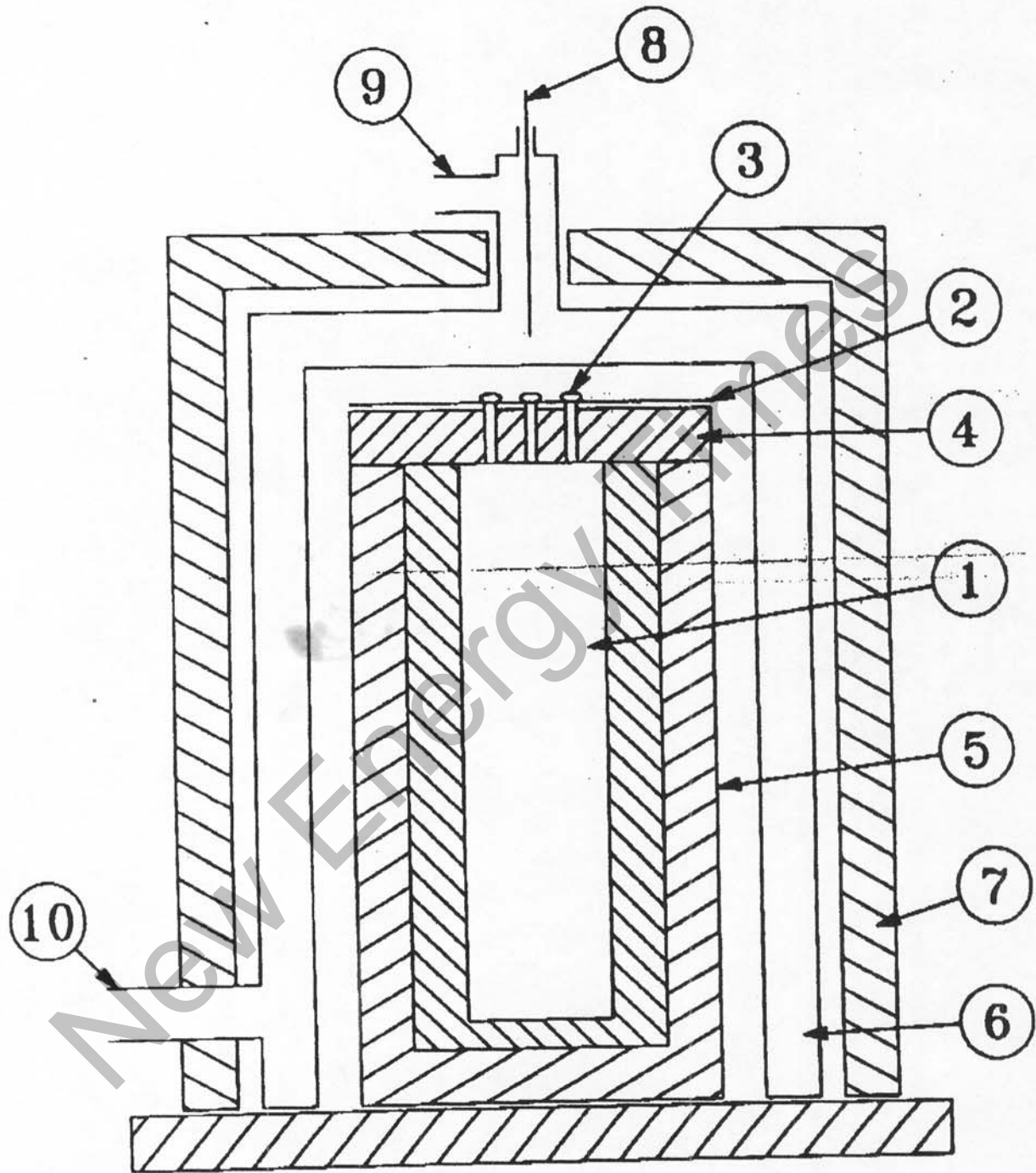

- | | |
|-------------------------------|-----------------------------|
| (1) ALUMINUM CYLINDRICAL CELL | (6) WATER JACKET |
| (2) ALUMINUM PLATE | (7) INSULATION |
| (3) BRASS BOLTS | (8) WATER TEMPERATURE PROBE |
| (4) INSULATION | (9) WATER OUTLET |
| (5) INSULATED CHAMBER | (10) WATER INLET |