

Anomalous production of gaseous ^4He at the inside of “DS-cathode” during D_2O -electrolysis

By Yoshiaki ARATA, M.J.A., and Yue-Chang ZHANG Cooperation Research Center for Advanced Science and Technology, Osaka University,

11-1 Mihogaoka, Ibaraki, Osaka 567-0047 (Contributed by Yoshiaki ARATA, M. J. A., Dec. 13, 1999)

Abstract: Observations were made of the abundant production of gaseous ^4He inside a double-structure Pd cathode (“DS-cathode”) which continuously had released excess heat of about 5~ 10 W over 2,000 hrs in the electrolysis of D_2O . These ^4He atoms were found from the inner atmosphere within the DS-cathode included the highly deuterated Pd fine powders.

Key words: Double-structure cathode; deuterated Pd; Pd black; electrolysis; excess energy; ^4He production

Introduction. In a recent paper we reported that a significant amount of excess heat (5-10 W) was produced continuously over 2,000 hrs when a double-structure Pd cathode (“DS-cathode”) was used in the electrolysis of D_2O .¹⁾ Furthermore, we observed production of ^4He atoms in the remnant Pd fine powders (Pd black) after the electrolysis.²⁾ These anomalous phenomena were not found in the electrolysis of H_2O in the same setting and procedure. The DS-cathode, which consisted of an outer cylindrical vessel of Pd metal (wall thickness of 3 mm) and Pd fine powders enclosed under a high vacuum, was invented to be embedded high-density deuterium in metallic fine powders.³⁾⁻⁵⁾ In the previous experiments we observed ^4He only from the remnant Pd powders after evacuation and heating, and thus, no information was obtained on the inner gas, which might have contained ^4He as well. In the present paper, we report on an experiment in which we succeeded in capturing the gaseous residue inside the DS-cathode in an isolated vacuum chamber to measure the ^4He component of the gas phase in the first experiment; type [A]. We also succeeded in capturing directly any time the inner atmosphere gases including ^4He inside the DS-cathode during electrolysis in the second experiment; type [B].

Type [A] experiment. We made a cathode piercing system for this purpose, as shown in Fig. 1. It was a flexible vacuum tank (FT) with SUS bellows to allow the DS-cathode to be pierced from outside using a handle **A**. The total volume of FT including the connecting pipes was ~200 cc. The top **B** and bottom **C** plates each equipped with a sharp drill and sandwich the upper and lower parts of the DS-cathode. In this way the DS-cathode was punctured and the inner gas diffused into the FT through a small hole (“pinhole”). The FT was connected through a standard vessel (SV) of 1.1 cc to a closed QMS (quadrupole mass spectrometer) system. All these parts were connected via vacuum valves. Vacuum pumps including a Ti getter pump as well as pressure gauges were also equipped, as shown in Fig. 1.

The experiment was carried out in the following steps. A DS-cathode with the inner volume of ~2.5 cc (8 mm in inner diameter and 50 mm in length), enclosing ~2.5 g of Pd fine powders of about 20 nm diameter, was immersed in heavy water for electrolysis. An excess heat of 5~10W was continuously observed over 2,000 hrs under 5.5 A electrolytic current. The total excess energy produced in the DS-cathode was estimated to be about 30 MJ. After the electrolysis was finished, the DS-cathode was housed inside the FT, which was then evacuated. After 20 hours in a high vacuum (about 10^{-8} torr), the FT was disconnected from the pumping line. The inner pressure gradually increased due to the diffusion of D_2 gas still left inside the DS-cathode through the Pd wall. When the pressure in FT reached 3 Torr, the gas was transported to the standard vessel (SV), which had been evacuated to 10^{-9} torr. This amount of gas (3 torr, 1.1 cc) was then introduced into the closed QMS system.

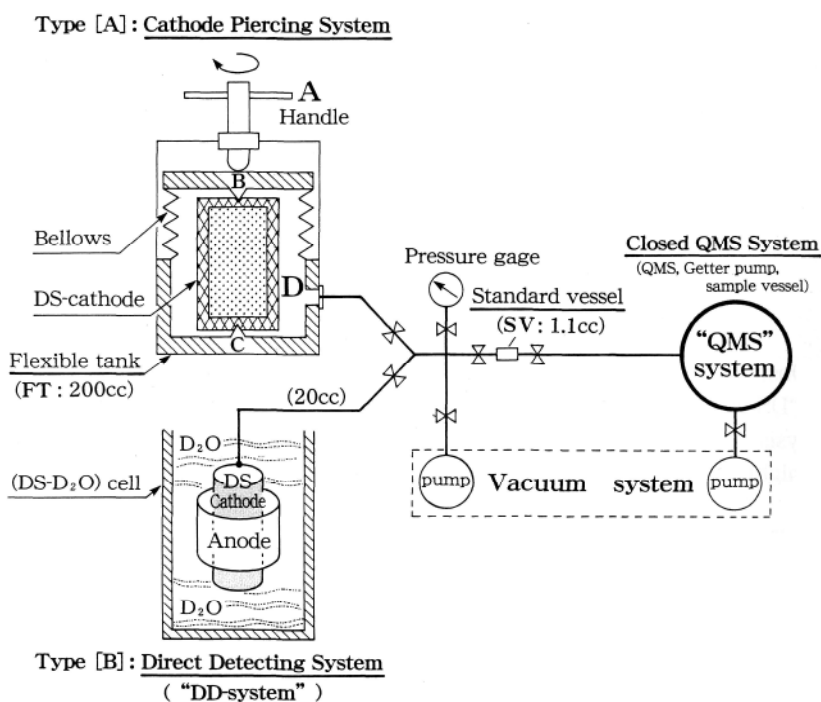

Fig. 1. Layout of the DS-cathode piercing system used in the present experiment. A flexible tank (FT) with bellows encloses a DS-cathode, which can be pierced with sharp drills by pushing the top plate **B** to the bottom plate **C** without breaking the vacuum by using a handle **A**. The FT is connected to the standard vessel and the QMS system. The valves, pressure gauge and vacuum system also shown.

The $M = 4$ coupled spectrum involving D_2 and ${}^4He^+$ was repeatedly measured (every 10 s) by a high-resolution QMS. The time-dependent spectra of the diffused D_2 gas through the Pd wall of the DS-cathode before the piercing process, are shown in Fig. 2A. Since the QMS chamber was continuously evacuated by a Ti getter pump, all the hydrogenic and organic molecules dissipated quickly, and only inert gases remained. The spectra shown in the figure were taken at the elapsed times, $\tau_1 = 200$ s, $\tau_2 = 400$ s and $\tau_3 = 800$ s, after the introduction of a sample gas of 1.1 cc into the closed QMS system. At $t = \tau_3$ there was no residual $M = 4$ component (much less than 1×10^{-12} A). It indicated that there was no trace of 4He in the diffused gas from inside the DS-cathode. The gas was D_2 only. This measurement assured that there is no detectable background of 4He existed in the present method.

Next, the DS-cathode was punctured by squeezing the upper **B** and lower **C** plates of the **FT**. This apparently created a "pinhole" ($\sim 20 \mu$) through which the inner gas filled the whole volume of **FT**. The movable plate **B**, was then moved back to allow better conductance of the inner gas through the produced hole. The equilibrium pressure of **FT** at the time of this opening was about 1.1 bar. This means that the inner pressure of the DS-cathode before its opening was as high as 88 bar. The $M = 4$ spectra taken with a small portion of the gas transferred through the SV [1.1 cc \times 30 torr] taken immediately after the opening are shown in Fig. 2B. There was a large amount of D_2 , which decreased quickly. At $t = \tau_3$ still a small amount of D_2 remained, while a slight amount of 4He was observed. However, the gas sample (SV [1.1 cc \times 1.1 bar]) taken at 5 hrs after the opening showed strikingly different spectra, indicating the presence of a large amount of 4He gas. The observed 4He was comparable in intensity with D_2 at $t = T_3$ as shown in Fig. 2C. The $M = 4$ spectra of the gas (SV [1.1 cc \times 1.1 bar]) taken at 134 hrs after the opening, which are shown in Fig. 2D, are even more striking. The 4He component at $t = T_3$ overwhelmingly dominated the $M = 4$ spectra. Because of the smallness of the hole ($\sim 20 \mu$) produced by piercing, the gas contents inside and outside the DS-cathode may be different. The change among spectra in Fig. 2B, C and D can be attributed to a long time constant for attaining equilibrium distribution of D_2 and 4He in the **FT**. Also a time dependent increase of the pressure inside **FT** was observed, which was due to still highly deuterated Pd

powders which kept emitting deuterium gradually.

Since the intensity of ^{22}Ne serves as a good indicator for possible ^4He contamination from the air, we always monitored its intensity. No detectable ^{22}Ne was observed, and thus, no detectable ^4He of air origin was present in the sample gas. Therefore, a large amount of ^4He gas was clearly detected from inside the DS-cathode.

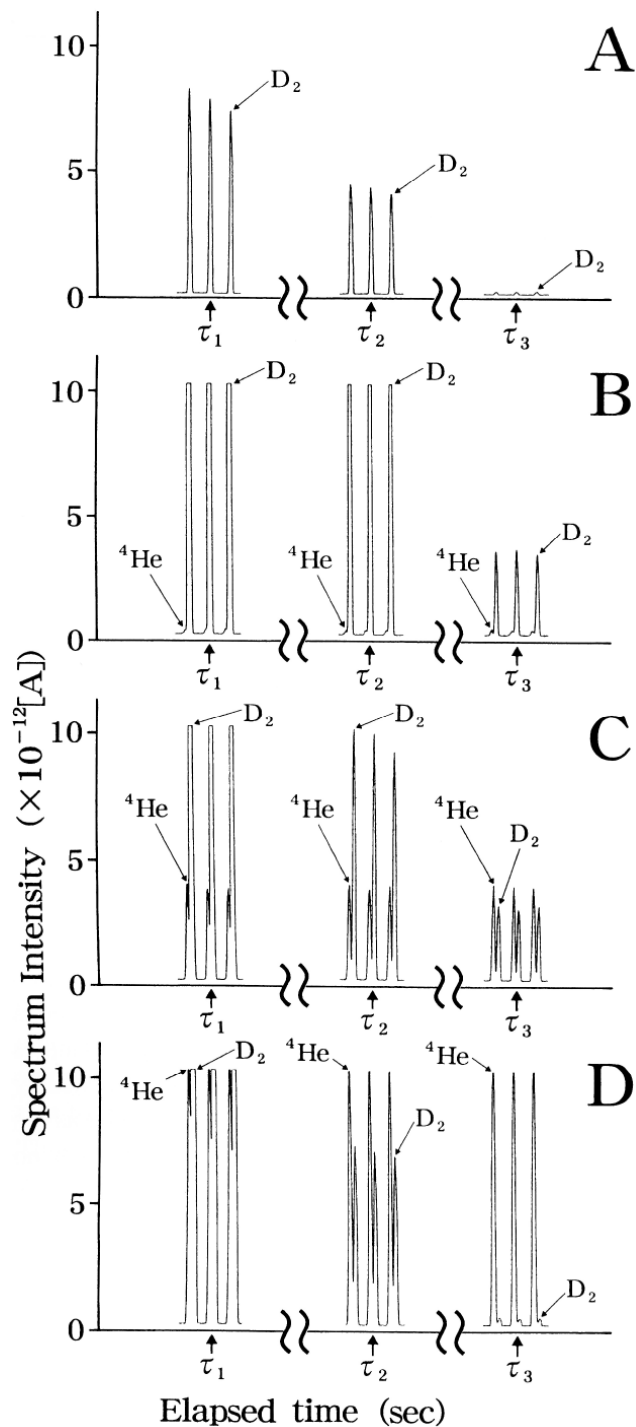

Fig. 2. The $M = 4$ coupled spectra of QMS taken at different elapsed times ($\tau_1 = 200$ s, $\tau_2 = 400$ s and $\tau_3 = 800$ s) after introduction of respective sample gases. A: 1.1 cc at 3 Torr before piercing, B: 1.1 cc at 30 Torr taken immediately after piercing, C: 1.1 cc at 1.1 bar taken at 5 hrs after piercing, and D: 1.1 cc at 1.1 bar taken at 134 hrs after piercing.

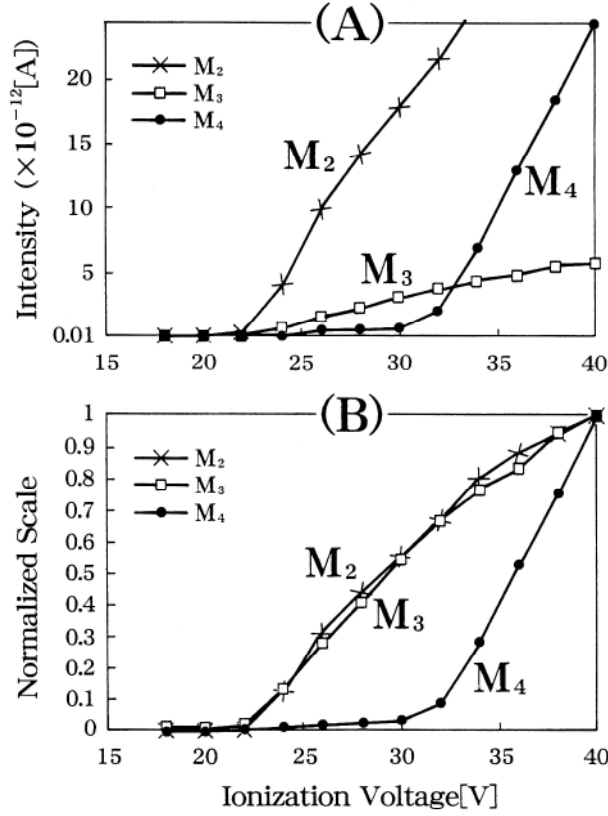

Fig. 3. I-V curves (“Vi-effect”), for M = 2, 3 and 4 groups taken at 5 minutes after $t = T_3$ on the sample gas Fig. 2D. The upper figure (A) is for absolute currents and the lower one (B) normalized. The group M₂ contains D and H₂. The M₃ is found to be mostly HD, while the group M₄ is mainly ⁴He.

Measurements were repeated many times over one month as shown in Table I, and it was found that after several days the sample gas of 1.1 cc and about 1 bar always contained nearly the same amount of ⁴He gas, namely, 1.2×10^{-11} A QMS current, which corresponds to 1.2×10^7 cc @STP. The total amount of ⁴He gas inside FT after piercing the DS-cathode is at least thus 200/1.1 times more, namely, 2.2×10^5 cc @STP.

In the second step, we examined whether or not the DS-cathodes still contained more ⁴He gas. For this purpose, we squeezed the plates, B and C, again to close the pinhole and evacuated the FT. When the vacuum inside FT reached $\sim 10^{-7}$ Torr, we disconnected the pumping line and opened the pinhole once more to release the remaining gas inside the DS-cathode into FT. The pressure in the FT became 0.1 bar. We took 1.1 cc of this gas and measured the mass spectra by the QMS system, in the same way as before. The intensity of ⁴He was found to be $> 10^{-11}$ A, as shown in Table I.

Therefore, at this time, the total amount of ⁴He gas released in the first and second steps is

$$V(^4\text{He})_{obs} > \sim 4.4 \times 10^{-5} \text{ cc @ STP}, \quad [1]$$

$$n(^4\text{He})_{obs} > \sim 1.2 \times 10^{15} (= 2.0 \times 10^{-9} \text{ mol}). \quad [2]$$

The clear observation of ⁴He gas supports and is consistent with the previous observation of ⁴He which was emitted by heating the remnant Pd powders. The amount of ⁴He gas detected in the present experiment, however, is at least 20 times larger than the previous one observed in heated remnant Pd fine powders. In the previous experiment the D₂⁺-⁴He⁺ coupled spectrum showed a long-lived D₂ component due to a slow release of D from inside the heated Pd fine powders. Contrarily, in the present experiment, every coupled spectrum showed a quickly

decreasing D, peak. Thus, the measurements were found to be much simpler.

Table I. Intensities of mass M_4 of the inner gases inside DS-cathode

Parameter 1999. Oct.	Gas Pressure [SV : 1.1 cc]	Intensity [A] Mass 4 ($\times 10^{-8}$)	Intensity [A] ${}^4\text{He}$ ($\times 10^{-11}$)	${}^4\text{He}/\text{D}_2$ ($\times 10^{-3}$)	Remark	
Type [A] Cathode Piercing System						
A	1	3 [torr]	1.0	0	0	Before piercing
	2	30 [torr]	7.5	0.1	0.01	I After piercing (pinhole open) immediately measured
	4	1.1 [atm]	2.8	1.7	0.6	
	5	1.1 [atm]	2.3	1.2	0.5	
	6	1.1 [atm]	2.7	1.5	0.6	
	7	1.1 [atm]	2.3	2.8	1.2	
	8	0.9 [atm]	15.0	1.7	0.1	II Intermittent measuring
	15	0.75 [atm]	2.5	0.8	0.3	
	18	0.7 [atm]	3.6	0.7	0.2	
	25	0.4 [atm]	0.15	3.1	20.7	
B	26	Pinhole close, and FT tank was vacuumed to $\sim 10^{-7}$ torr, then pinhole open, FT heat to ~ 250 °C for 30 min, and thus FT pressure rised to ~ 1.2 [atm], decreased to 0.1 [atm] at R.T.			Gas renewal inside FT	
C Nov.	28	0.1 [atm]	0.69	1.2	1.7	Intermittent measuring
	2	0.05 [atm]	0.10	2.5	25.0	
D	4	Pinhole open, and FT tank was vacuumed to $\sim 10^{-7}$ torr, and heated to ~ 300 °C for 3 hours, thus FT pressure rised to 0.6 [atm] at R.T.			Gas renewal inside FT	
E	4	0.6 [atm]	0.89	5.6	6.3	Intermittent measuring
	8	0.04 [atm]	1.1	8.3	7.5	
Type [B] Direct Detecting System						
F	11	0.05 [atm]	0.1	1.5	15.0	Intermittent measuring
	11	0.05 [atm]	0.12	2.2	18.3	
	15	9.4 [torr]	0.1	2.2	22.0	

In order to examine whether ${}^3\text{He}$ were produced in comparable amount of ${}^4\text{He}$ or not, we used the method as follows. In spite of the mass resolution of QMS was not high enough to resolve ${}^3\text{He}$ and DH in the $M = 3$ group, the components can be separated clearly from the dependence of the ion current on the ionization voltage (I-V curve) because of the difference of the ionization energy between hydrogen and helium. Fig. 3 shows observed I-V dependence of the $M = 2, 3$ and 4 groups taken at 5 minutes after $t = \tau_3$ on the respective samples in Fig. 2D as indicated. Clearly, the M_4 group is mainly ${}^4\text{He}$, while the M_3 group showed the same behavior as the M_2 group witch contains D and H_2 , indicating that no detectable ${}^3\text{He}$ was present in M_3 group; it was mostly HD. This conclusion was also supported by the fact that the ion current intensity of M_3 group decreased with elapsed time τ in parallel with that of D_2^+ .

In the last step, we examined whether the ${}^4\text{He}$ still remained or not in DS-cathode. For this purpose, we heated outer surface of FT tank with low temperature (≤ 300 °C), and the measuring process was same as before. As a result, the amount of ${}^4\text{He}$ was observed several times larger than that of observed in at the first step, as shown in Table I (E). The total amount of ${}^4\text{He}$ is

$$V({}^4\text{He})_{obs} > \sim 2.1 \times 10^{-4} \text{ cc @ STP}$$

$$n({}^4\text{He})_{obs} > \sim 5.7 \times 10^{15} . \quad [3]$$

Consequently, characteristics of the residual gases inside DS-cathode were made clear through the experiment over one month as demonstrated in Table I.

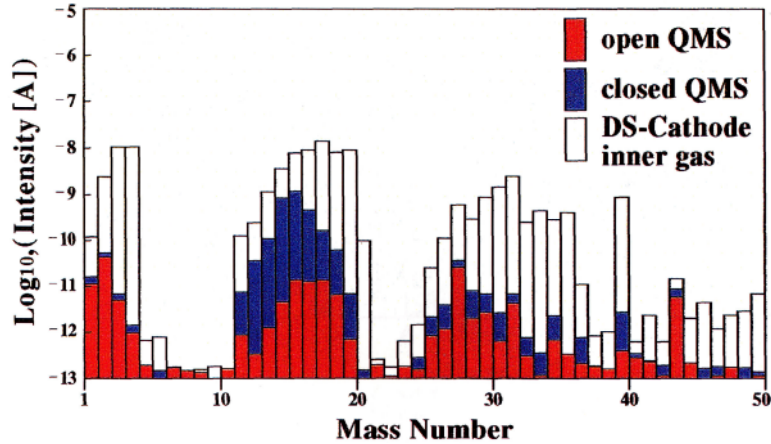

Fig. 4. Bar-graph of mass number (1-50) inside QMS.

Type [B] experiment. We also succeeded in capturing and measuring directly the inner gases of DS-cathode during electrolysis. The DS-cathode in type [B] was open type, in which inner pressure was monitored by a pressure gauge and the inside gases can be used intermittently to examine the content by the QMS system. Table I (F) was obtained directly from DS-cathode which generated inner pressure of 300 bar and excess energy of 2-5 watts, over 2,000 hrs during electrolysis in [DS-D₂O] cell and similar diagrams to Fig. 2 and Fig. 3 were obtained.

The conclusion, we have observed a substantial amount of gaseous ⁴He from the inside of the DS-cathode after electrolysis over 2,000 hrs in D₂O. The amount of gaseous ⁴He is about two orders larger than that found previously from the heated fine Pd powders. Thus, in the previous and present experiments we have demonstrated that the ⁴He is certainly produced in the inside of DS-cathode. Because of the slow release of ⁴He from the fine Pd powders, it is extremely interesting to investigate remaining ⁴He inside the DS-cathode, in particular, ⁴He in the surface region of the Pd fine powders, further experiments are in progress.

Appendix I. Characteristics of QMS system in present experiment. Fig. 4 is bar-graph demonstrating basic characteristics of “QMS” system for a mass range: 1-50. In Fig. 4, red-bar shows distribution of mass intensity which indicate characteristics of “open-QMS” system under $\sim 10^{-9}$ Torr during pumping action, blue-bar that of “closed-QMS” system, and white-bar that of inner atmosphere generated inside DS-cathode.

Appendix II. Fundamental differences between Bulk-cathode and DS-cathode in process of deuterium (hydrogen) absorption and occlusion. Radial dependence of “D(H)-concentration” of cylindrical cathodes having identical external shape are illustrated in Fig. 5. Although both cathodes are of identical external shape (cylindrical) and size, their deuterium absorption mechanism is substantially different. Because the Bulk-cathode solely relies on its “diffusion-effect”, it is practically impossible to reach 100 [at %] concentration using bulk-solid under a solid-solution state in the course of time, as illustrated in the left side of the Diagrams [A], [B], [C] and [D] in Fig. 5.

DS-cathode, enclosing cylindrical cell filled with Pd-black (atom-cluster), functions in exactly the same way as Bulk-cathode until deuterium reaches inner wall (Fig. 5 [A]). Then, its reaction mechanism shows a dramatic change. The D-ions, which infiltrated into the cell, disperse with impetuous speed over the surface of the Pd-black due to “spillover-effect” without becoming D₂ molecules. At the same time, they are absorbed in each particle quickly. As the D-ions are gradually saturated, they accumulate as D₂ gas among the particles gaps, and after 10-20 hours the inner pressure increase to several thousand atm. The effect known as the Sievertz law causes a continual rise in pressure {P} as the D₂ molecules until it is proportionate with the solid-state concentration, {D}, of inner surface layer of DS-cathode. This process is illustrated in the right side of the Diagrams [A], [B], [C] and [D] in Fig. 5 (pressure in shown as $P (= n k T) \propto n$ (density)). If the temperature (T) is maintained constant, it will become proportionate to the concentration, and moreover the deuterium concentration in Pd-black, {C}^{*}, increases easily beyond 100 [at %] due to the functions of “Atom-cluster”.

Therefore, we believe that these essential differences between the mechanism of both types of cathodes are decisive in realizing solid-state nuclear fusion.

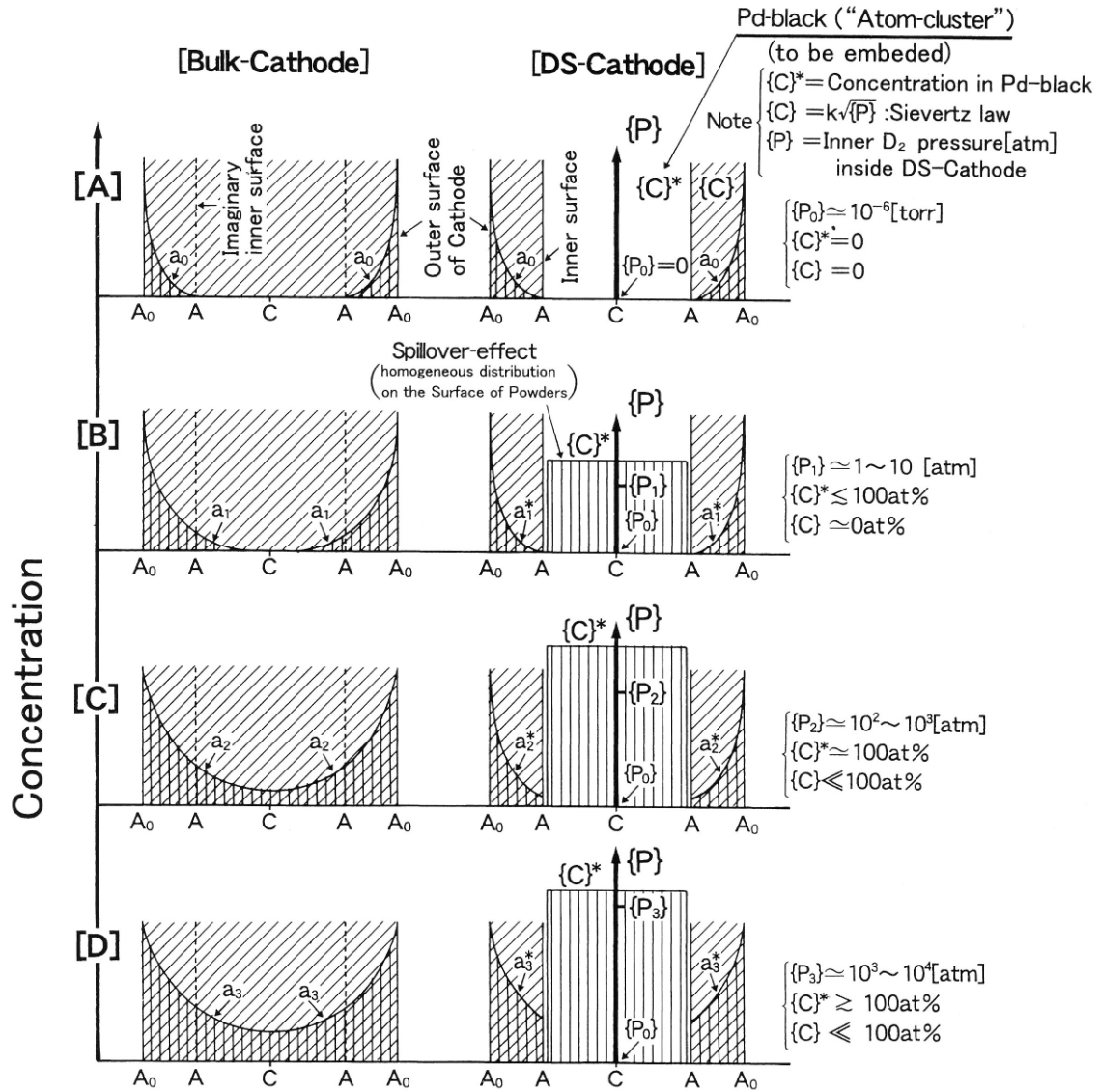
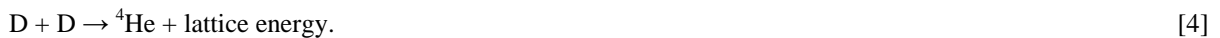

Fig. 5. Definitive difference of deuterium absorption Bulk-cathode and DS-cathode. Note: Longitudinal sections of cylindrical cathodes having identical external shape are illustrated with the distribution of deuterium concentration.

Some years ago, we have presented on deuterium reaction process developed within a host metals, as the result of deuterium solid-state plasma fusion as follows^{4),5)};



Acknowledgements. The present study was conducted through a research grant from the Japan Society for the Promotion of Science. The authors would like to thank Drs. K. Sugimoto and T. Yamazaki, Professors Emeritus of the University of Tokyo, Dr. H. Fujita, Professor Emeritus of Osaka University, and Prof. T. Yokobori, M.J.A.

References

- 1) Y. Arata and Y.-C. Zhang (1998) Jpn. J. Appl. Phys. **37**, L1274-L1276.
- 2) Y. Arata and Y.-C. Zhang (1999) Jpn. J. Appl. Phys. **38**, L774-L776.
- 3) Y. Arata and Y.-C. Zhang (1994) Proc. Japan Acad. **70B**, 106-111.
- 4) Y. Arata and Y.-C. Zhang (1995) Proc. Japan Acad. **71B**, 304-309.
- 5) Y. Arata and Y.-C. Zhang (1997) J. High Temperature Soc. Jpn. (Special volume), pp. 1-56.